

VERTICAL SCISSOR LIFT

5.5 T ELECTRO-HYDRAULIC

Vertical scissor lifts of the V55 series are high-precision lifting platforms for wheel alignment and diagnostic workstations (assistance systems) with 5.5 t load capacity and 5400 mm

usable track length. Depending on the application, the V55 series is available in both above-ground and underfloor versions.

+ Perfect corrosion protection - KTL coating plus powder coating as standard
+ Lots of free space under the lift with side access

The control panel has a factory pre-assembled hydraulic power unit and thus contributes significantly to low installation costs. Placement is possible left or right.

Documents or even tablet computers find their place on the integrated storage facility of the control panel, which is also perfectly suitable as a desk pad. Stable pushbuttons ensure safe operation of the lift.

The construction provides maximum clearance under the lift and allows for lateral access.

Lift table - 4000 kg.



The lifting scissors close to the wheel contact surface and thus give the lift a very high stability. In conjunction with the precision-machined and reinforced running surfaces, it meets the specifications of the leading German car manufacturers.

The level lane allows the use at the head-lamp setting.

The standard CE-Stop ensures foot protection without a foot deflector and trouble-free floor-level installation.

Figure shows: Model V55LTAK54CAT

HIGHLIGHTS IN DETAIL

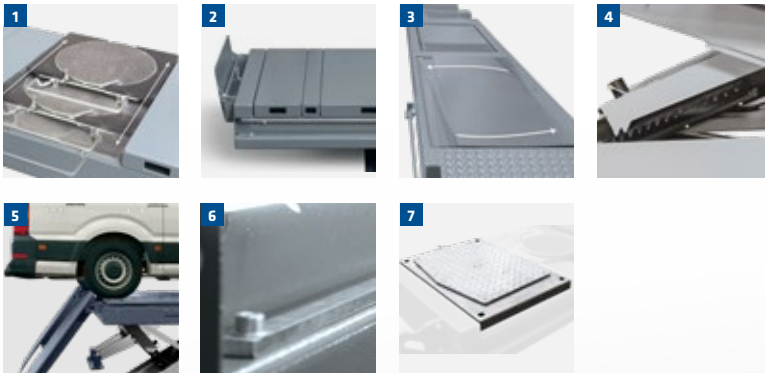

1 Integrated recesses with stainless steel overlays in the driving surface enable the inclusion of all commercially available turntables. The stainless steel surface avoids corrosion and allows effortless prescribing of the turntable.

2 If no turntable is used, the recesses can be completely closed. The patches are equipped with plastic stops to prevent corrosion and reduce noise.

3 Sturdy plastic balls of the pneumatically lockable sliding plates ensure reliable and smooth operation and ensure a long service life.

4 The master cylinders are equipped with a pneumatically operated settling device. The latch bar is screwed and adjustable via screws. An exact wheel alignment is guaranteed.

5 Intelligently designed roll-back locks allow the use of the complete track length.

6 To use an extra non-axle lift, a galvanized rail is installed on the platform.

7 8 movement play detector, 2014/45EU compliant.

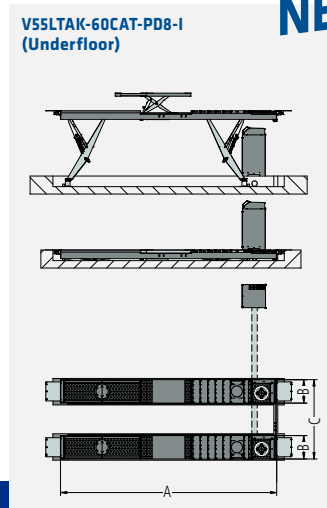
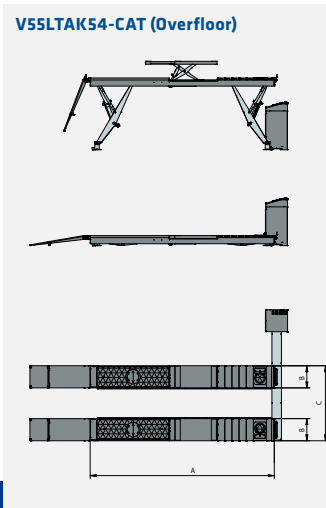
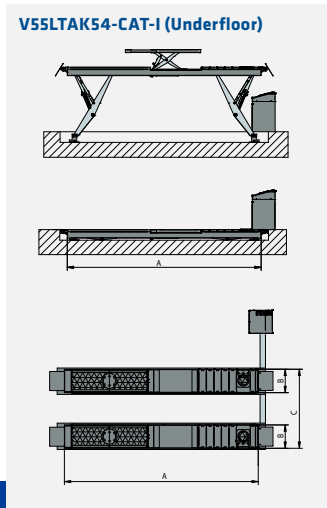

NEW

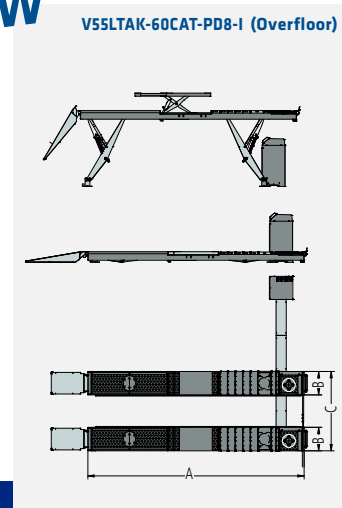

Model	V55AK54-CAT	V55LT54-CAT	V55LTAK54-CAT	V55LTAK-60CAT-PD8-I
Rated load capacity	5.500 kg	5.500 kg	5.500 kg	5.500 kg
Stroke	1.800 mm	1.800 mm	1.800 mm	1.800 mm
Lifting time loaded	35 sec.	35 sec.	35 sec.	35 sec.
Lowering time loaded	35 sec.	35 sec.	35 sec.	35 sec.
Drive-on/ drive-over height	295 mm**	295 mm**	295 mm**	295 mm*
Installation depth	305 mm*	305 mm*	305 mm*	295 mm*
A Platform length	5.400 mm	5.400 mm	5.400 mm	6.000 mm
B Platform width	650 mm	650 mm	650 mm	650 mm
C Overall width	2.200 mm	2.200 mm	2.200 mm	2.200 mm
Overall length - Overfloor	7.255 mm**	7.255 mm**	7.255 mm**	6000 mm
Lifting height of wheel free lift	-	490 mm	490 mm	490 mm
Platform length Jacking Beam	-	4000 kg	4000 kg	4000 kg
Rated load capacity of wheel free lift	-	1.390-2.100 mm	1.390-2.100 mm	1.390-2.100 mm
Driving power	4 x 2,6 kW	4 x 2,6 kW	4 x 2,6 kW	4 x 2,6 kW
Power supply voltage (electrical)	230/400 V, 50 Hz	230/400 V, 50 Hz	230/400 V, 50 Hz	775-230/400 V 50 Hz
Weight	2.310 kg	2.090 kg	2.670 kg	2.800 kg
Article number	820298*	820296*	820176*	820661*

* Underfloor ** Overfloor

AK = For wheel alignment, LT = With wheel free lift, LTAK = For wheel alignment with wheel free lift

ACCESSORIES



- 1 Lighting kit, 4 LED units, 24V.
- 2 Jacking beam, load capacity 2600 kg.
- 3 Ramp extension, long ramps for sports cars.
- 4 Rubber pads, T4, height 80 mm, 4 pieces.
- 5 Rubber pads, T4B, height 40 mm, 4 pieces.



Technical changes reserved. Data are considered advertisement. Vertical Scissor Lifts-V55-models-BR-127830-en-2021-06

